

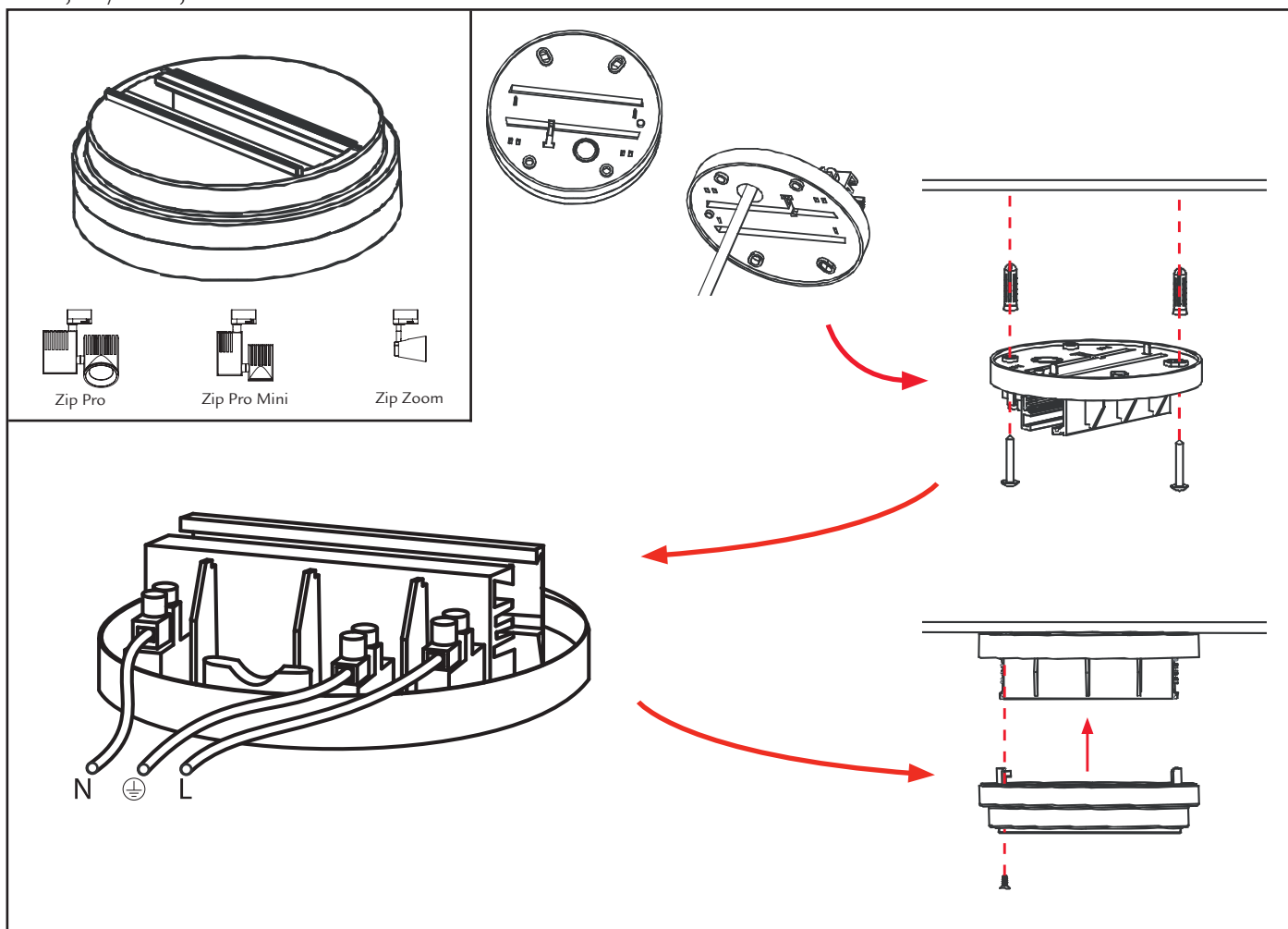

ShopLine 3-T Monopint



230V, 50/60Hz, 16A



NO: Skru av strømmen før montering
 EN: Turn off power before installing
 FR: Couper le courant avant l'installation
 NL: Stroom uitschakelen voor u het toestel installeert
 DE: Vor Installationsarbeiten den Strom abschalten.

NO: Systemet er kun beregnet for lysarmaturer og ingenting annet.
 EN: The system is only intended for light fixtures.
 FR: Le système est uniquement prévu pour des appareils d'éclairage.
 NL: Het systeem is uitsluitend voor verlichtingstoestellen bedoeld.
 DE: Das System ist ausschließlich für die Montage von Beleuchtung vorgesehen.



NO: Kan kun installeres av en registrert installasjonsvirksomhet.
 EN: Only to be installed by authorized personnel.
 FR: Doit être installé par un électricien autorisé.
 NL: Mag alleen geïnstalleerd worden door een bevoegde elektricien.
 DE: Dieses Produkt darf nur durch autorisiertes Personal (z. B. Elektro-Installateur) angeschlossen und in Betrieb genommen werden.

NO: Det er brukerens ansvar å sørge for elektrisk, mekanisk og termisk kompatibilitet mellom skinner-systemet og tilkoblede armaturer .
 EN: It is the user's responsibility to ensure electrical, mechanical and thermal compatibility between the track system and luminaires attached to it.
 FR: L'utilisateur doit s'assurer de la compatibilité électrique, thermique et mécanique entre le système Track et les luminaires qui lui sont rattachés.
 NL: Het is de verantwoordelijkheid van de gebruiker om na te gaan of the tracksystem en de gebruikte verlichtingstoestellen elektrisch, mechanisch en thermisch compatibel zijn.
 DE: Der Anwender/Elektroinstallateur hat sicherzustellen, dass die elektrische, mechanische und thermische Kompatibilität zwischen dem Schienensystem und den Leuchten gegeben ist.

CORPORATE OFFICE: SG Armaturen AS Svåbekk 15 4790 Lillesand NORGE Tlf:+47 37 50 03 00 firmapost@sg-as.no www.sg-as.no	BRANCH OFFICE: SG Lighting SA/NV Blokhuistraat 47 2800 Mechelen Noord I BELGIQUE/BELGIË Tlf:+32(0) 15 20 72 71 info.benelux@silighting.net www.silighting.net	BRANCH OFFICE: SG Armaturen A/S Egebakken 19 7400 Herning DANMARK Tlf:+45 70 70 72 13 info@sg-as.dk www.sg-as.dk	BRANCH OFFICE: SG Lighting SA/NV 73 rue de Saint Mandrier 83140 Six Fours Les Plages FRANCE Tlf:+33(0) 4 94 93 00 00 info.france@silighting.fr www.silighting.net	BRANCH OFFICE: SG Leuchten GmbH Postfach 67 04 21 22344 Hamburg GERMANY Tlf:+49 40 23 99 44 59 info@sg-leuchten.de www.sg-leuchten.de	BRANCH OFFICE: SG Armaturen AB August Barksg. 30B 421 32 Västra Frölunda SVERIGE Tlf:+46 31 81 71 10 info@sg-ab.se www.sg-ab.se
---	---	--	---	---	---

Rev: 26.05.2016